

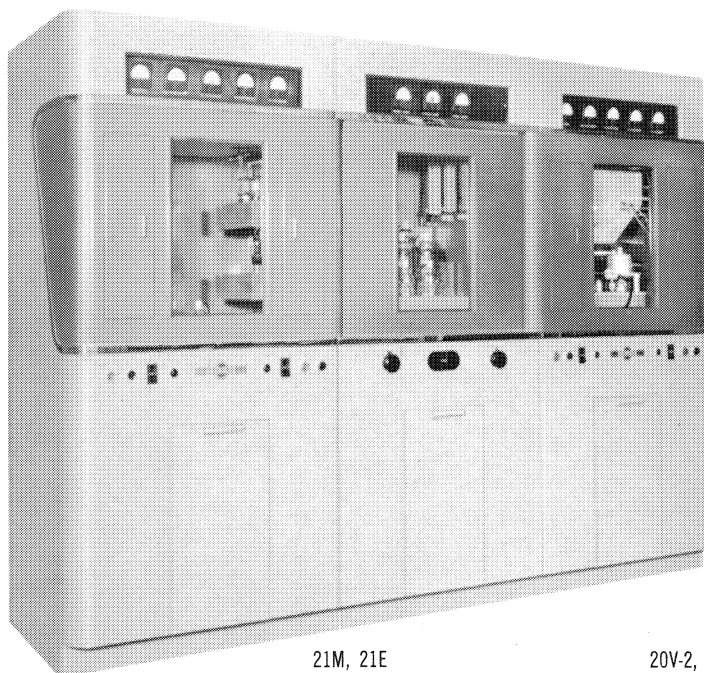

Radio Station KTKT, Tucson

# COLLINS broadcast equipment

# BROADCAST TRANSMITTERS



21M, 21E

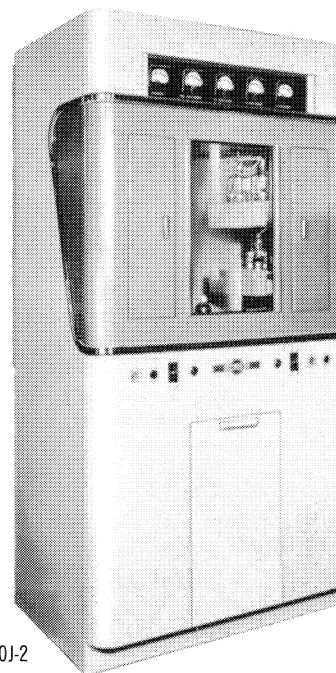

20V-2, 550A-1, 300J-2

Reliable, high fidelity performance in the standard and HF broadcast bands is the result of the straightforward design and modern components in the Collins line of broadcast transmitters. All transmitters may be equipped for remote control. Power increase packages enable fast changeover of 21E 5 kw to 21M 10 kw, 550A-1 500 watt to 20V-2 1 kw, 300J-2 250 watt to 550A-1 500 watt or 20V-2 1 kw.

**21M 10 KW TRANSMITTER** — Offers selectable power output of 10,600 or 5,500 (1,100 on order) watts. Highly stable vacuum crystals eliminate crystal ovens. Pi-L output network. *Frequency Range:* 540-1600 kc standard; up to 10 mc available. *Primary Power:* 208/230 v, 3 phase, 60 cps (50 on order), 32.8 kw (at 10 kw output, 100% mod.), 91.5% PF.\*

**21E 5 KW TRANSMITTER** — Selectable power output of 5,500 or 1,100 (550 on order) watts with same features and coverage as 21M. *Primary Power:* 208/230 v, 3 phase, 60 cps (50 on order), 18.5 kw (5 kw output, 100% mod.), 90% PF.\*

**20V-2 1 KW TRANSMITTER** — Output power of 1,100 or 550 (275 on order) watts may be selected. 20V-2 uses only 7 tube types, no crystal ovens. *Frequency Range:* 540-1600 kc standard; up to 15 mc available. *Primary Power:* 208/230 v, 1 phase, 50/60 cps, 4,150 watts (at 1,100 watts output, 100% modulation), 90% PF.\*

**550A-1 500 WATT TRANSMITTER** — Either 550 or 275 (125 on order) watts output power may be selected. Stable oscillator, pi-L output network. *Frequency Range:* 540-1600 kc standard; up to 15 mc available. *Primary Power:* 208/230 v, 1 phase, 50/60 cps, 2840 watts (at 550 watts output, 100% modulation), 83% PF.\*

**300J-2 250 WATT TRANSMITTER** — Selectable power outputs of 275 or 110 watts. Only 7 tube types, no crystal ovens.

*Frequency Range:* 540-1600 kc standard; up to 15 mc available. *Primary Power:* 208/230 v, 1 phase, 50/60 cps, 1,400 watts (at 275 watts output, 100% modulation), 90% PF.\*

**\*COMMON SPECIFICATIONS (21E/M, 20V-2, 550A-1, 300J-2)** — *Frequency Stability:* Better than  $\pm 5$  cps (typical  $\pm 2$  cps). *Audio Frequency Response:* Within  $\pm 1\frac{1}{2}$  db 30-12,000 cps (typical  $\pm 1\frac{1}{2}$  db 30-15,000). *Audio Frequency Distortion:* Less than 3% 50-10,000 cps for 95% modulation, including all harmonics up to 16 kc (typical less than 3% 30-15,000). *Residual Noise Level:* 60 db or more below 100% modulation. *Carrier Shift:* Less than 3% 0-100% modulation (typical less than 2%). *RF Output Impedance:* 50-240 ohms standard; 600 ohms balanced on order. *Audio Input Impedance:* 150/600 ohms.

Transmitter Type	Dimensions (inches)			Weight (lbs.)	Power Output (watts)
	W	D	H		
21M	105¼	28	76	3,000	10,600/5,500 (10,600/1,100**)
Plate Xformer	24½	12½	31¾	Included above	.....
21E	105¼	28	76	2,700	5,500/1,100 (5,500/550**)
Plate Xformer	20½	10¾	25¾	Included above	.....
20V-2	38	27	76	1,150	1,100/550 (1,100/275**)
550A-1	38	27	76	1,050	550/275 (550/125**)
300J-2	38	27	76	900	275/110

\*\*On special order.

# TRANSMITTER ACCESSORIES

**37M FM ANTENNAS** — Light, compact structure reduces tower requirements, windloading and erection problems. The 37M consists of radiating rings supported on a connecting inter-ring transmission line. Any number of rings, odd or even, may be employed for desired gain. High tuning stability maintains VSWR at better than 1.1 to 1. May be mounted on top or side of tower. *Power Rating:* Arrays up to 20 kw. *Termination:* 51.5 ohm flange.

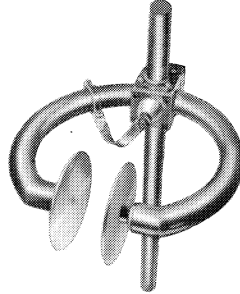

**SIDE MOUNTING\***

Antenna Type	No. of Rings	Power Gain	Field Gain	A (feet)	On 1 5/8" Line B	On 3 1/8" Line B	Weight	Weight
37M-1	1	.9	.95	2-6 ±	24	23	32	46
37M-2	2	2.0	1.41	12-6 ±	68	55	100	100
37M-3	3	3.0	1.73	22-6 ±	114	86	170	175
37M-4	4	4.1	2.02	32-6 ±	160	119	240	240
37M-5	5	5.2	2.28	42-6 ±	206	152	310	305
37M-6	6	6.3	2.51	52-6 ±	252	185	380	370
37M-7	7	7.3	2.70	62-6 ±	298	218	450	435
37M-8*	8	8.4	2.90	72-6 ±	344	251	520	500

\*Top mounting antennas or antennas with more than eight rings quoted upon request.  
A = over-all length B = windloading

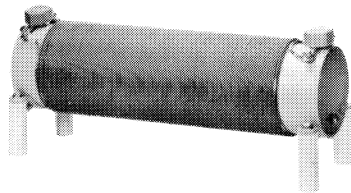

**TOWER LIGHTING FILTER CHOKES** — Solenoid wound chokes with high impedance in broadcast band. Wound with #10 wire, available 2 or 3 wire. *Power Rating:* 120 v, 1 phase, 2,000 watts.

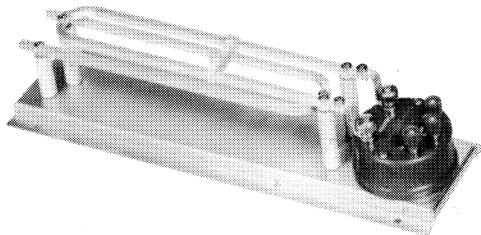

**ANTENNA CURRENT TRANSFORMER** — Used with remote thermocouple and meter for remote monitoring of antenna current. For currents up to 25 amps.

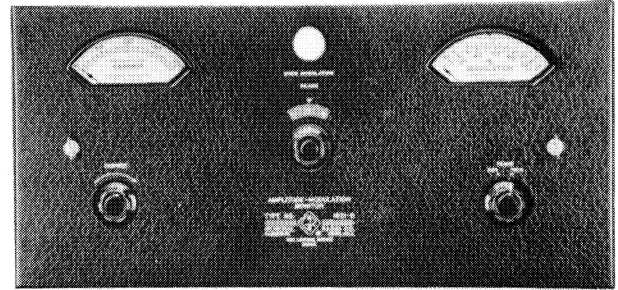

**1931-B AM MODULATION MONITOR** — Measures percent-age modulation on positive or negative peaks, indicates over-modulation, monitors program level and measures transmitter audio frequency response and carrier shift when modulation is applied. Operates in 0.5 to 8 mc range. *Primary Power:* 105-125 v, 50/60 cps, 50 watts. *Size:* 19" W, 10" D, 8 3/4" H. *Weight:* 32 lbs.

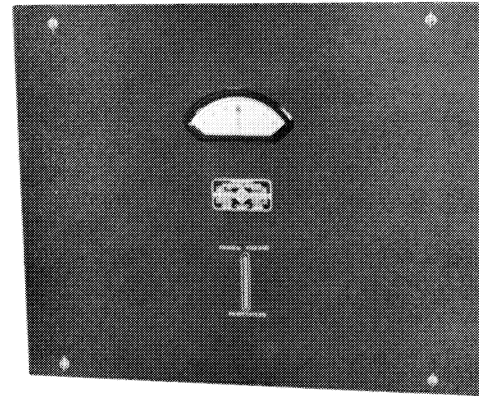

**1181-B FREQUENCY DEVIATION MONITOR** — Gives direct indications of magnitude and direction of frequency deviation of AM transmitter. Positive indication is provided for failure of either transmitter carrier or monitor crystal oscillator. *Frequency Range:* 0.5-2 mc (specify crystal frequency). *Deviation Range:* ±30 cps. *Primary Power:* 105-125 or 210-250 v, 50/60 cps, 125 watts. *Size:* 19" W, 13" D, 15 3/4" H. *Weight:* 51 lbs.

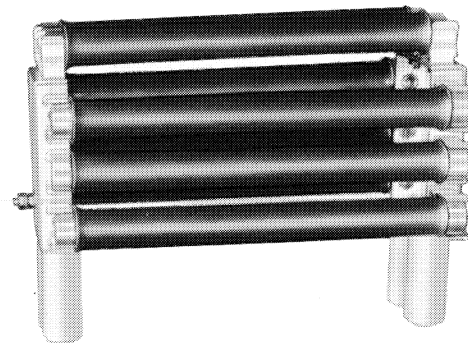

**172G-1, -2 DUMMY LOADS** — This air-cooled unit provides a load to dissipate transmitter output for off-the-air testing. Consisting of 8 ferrule type, non-inductive resistors, with insulated end brackets and clips, it may be mounted on the transmitter or adjacent wall. The 172G-1 has an impedance of 52 ohms; the 172G-2, 73 ohms. *Power Rating:* Up to 1 kw. *Size:* Approx. 6" W, 12 1/2" D, 9" H. *Weight:* 5 lbs.

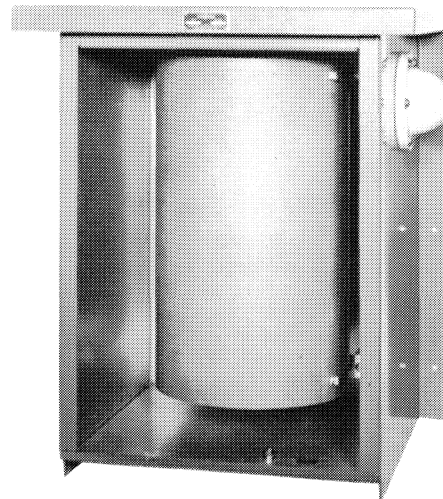
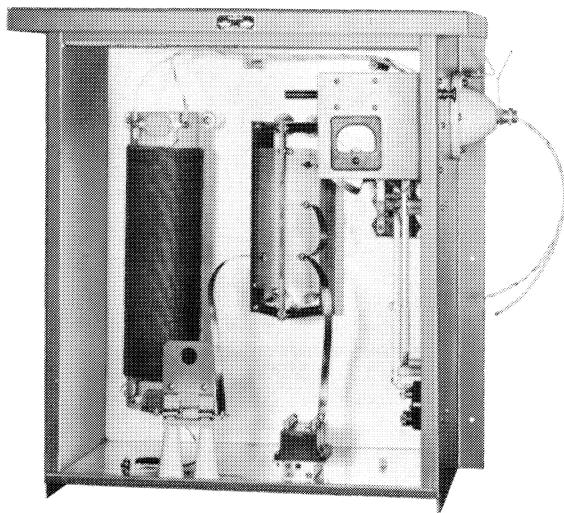

**42E-7, -8 ANTENNA COUPLING UNITS** — Use a low pass T network to match a series fed vertical radiator to an unbalanced transmission line. The 42E-7 (pictured) is used up to 1 kw; the 42E-8, 5 or 10 kw. Includes antenna current meter and line current meter jack and will house tower lighting filter choke and antenna current transformer. *Size:* 42E-7 — 29" W, 18" D, 28" H. 42E-8 — 36" W, 22" D, 28" H. *Weight:* 42E-7 — 64 lbs. 42E-8 — 124 lbs.

**144A-1 ISOLATION COIL** — Coil provides isolation for the sampling line in directional arrays, presenting a high impedance for the line across the base insulator. Unit consists of a phenolic coil form which will accommodate 37 turns of RG8/U or similar solid dielectric sampling line. May be mounted on wall of tuning shack or in 49U-1 Housing (pictured). *Inductance:* Approx. 180 microhenrys. *Size:* 10" dia., 18" L. *Weight:* 6 lbs.

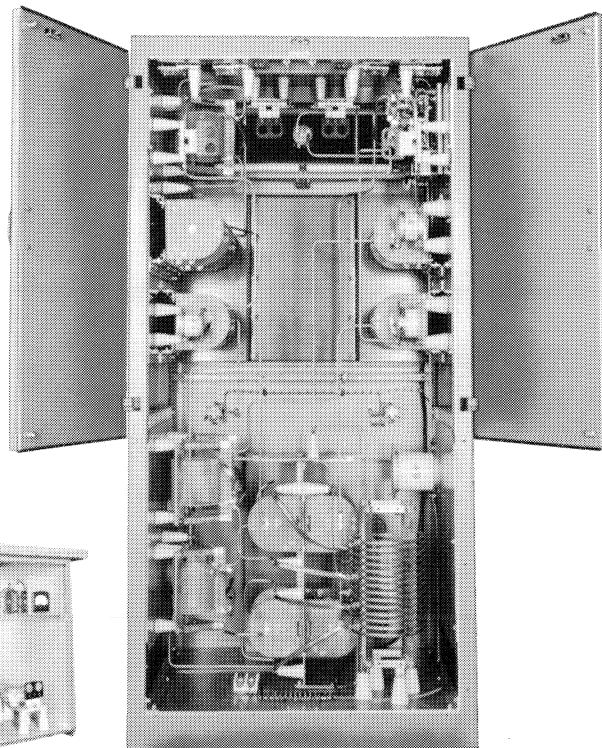

Rear View, 5 kw  
Phasor Cabinet

Antenna Tuner

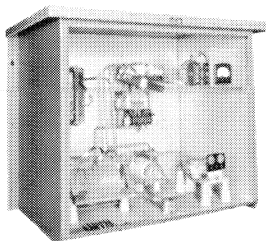

**81M PHASORS** — Custom designed Collins phasing equipment for directional antennas features easily adjusted networks, high stability, maintenance ease, safety and economy. Power dividing circuits and T phase shift networks utilize heavy edge-wound copper ribbon inductors and ceramic cased mica capacitors. Amplitude and phase adjustment controls are recessed counter dials with accurate resetability.

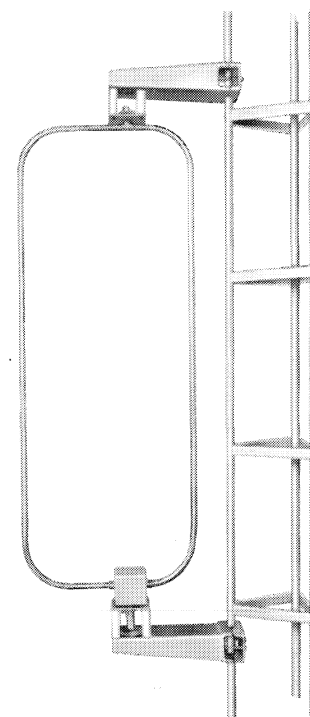

**564A-1 PHASE SAMPLING LOOP** — For accurate sampling of currents in directional arrays. Two loops of wire, connected in series or parallel, inside a copper tubing shield which eliminates electrostatic coupling. Connects with air or solid dielectric line. *Size:* Approx. 30" W, 7'6" H. *Weight:* 50 lbs.

**564A-2 PHASE SAMPLING LOOP** — An unshielded loop of galvanized iron pipe. *Size:* Approx. 42" W, 7'2" H. *Weight:* 35 lbs.

# SPEECH EQUIPMENT

Collins speech input consoles employ modular construction to offer AM, FM and TV broadcasters maximum flexibility. Starting with a minimum of modular subunits, the broadcaster may add or relocate subunits as required.

**212E-1 SPEECH INPUT CONSOLE**—This dual channel unit offers high fidelity program control in audio systems, with two output lines and mixing of up to 9 of 22 possible inputs simultaneously. Monitoring is provided for program, audition and remote lines, as well as controls for speakers and warning lights. There are also provisions for measuring external audio levels and for an external input to the monitor amplifier. Excellent frequency response and low noise and distortion are maintained from 50 to 15,000 cps. For ease of operation, controls are color coded, and write-in strips are provided. The console will accommodate up to seven preamplifiers plus booster amplifiers, program amplifiers, a monitor amplifier and a cueing amplifier (subunits discussed below). Where maximum console capabilities are employed, 499G-1 Rack Mounting Shelf provides additional space for mounting amplifiers, power supplies and relay units. *Input Impedance: Low Level*—30/150/250/600 ohms (balanced or unbalanced). *Remote Lines*—150/600 ohms. *Output Impedance: Line*—150/600 ohms. *Monitor*—600 ohms. (Shipped 600 ohm output and remote line, 150 ohm low level input.) *Gain: Low level to program line at least 100 db. Remote line to program line 54 db. Noise: No greater than -118 dbm at low level input. Primary Power: 115/230 v  $\pm$ 10%, 1 phase, 50/60 cps.*

**212F-1 SPEECH INPUT CONSOLE**—Simultaneous broadcasting and auditioning from any combination of three of eight possible inputs is provided by this single channel console, with capability of mixing five of 12 inputs by adding two preamplifiers. The 212F-1 also enables monitoring of program, audition or remote lines and control of speakers and warning lights. High fidelity performance is offered with low noise and distortion and excellent frequency response from 50 to 15,000 cps. All subunits (see below) can be mounted in the console. *Input Impedance: Low Level*—30/150/250/600 ohms (balanced or unbalanced). *Remote Lines*—150/600 ohms. *Output Impedance: Line*—150/600 ohms. *Monitor*—150/600 ohms. (Shipped 600 ohm program and remote lines, 150 ohm low level input.) *Gain: Low level to program line at least 100 db. Remote line to program line 50 db. Noise: No greater than -118 dbm at low level input. Primary Power: 115/230 v  $\pm$ 10%, 1 phase, 50/60 cps.*

## SUBUNITS

**356A-1 PREAMPLIFIER**—Operating from a low level microphone or similar source, this high fidelity, two stage unit can drive a program amplifier or audition facilities. *Input Impe-*

*dance: 30/150/250/600 ohms. Output Impedance: 150/600 ohms balanced or unbalanced. Input Level: -60 db nom. Output Level: +18 dbm max. Gain: 40 db. Noise: No greater than -118 dbm at input. Power Requirements: 6.3 v ac or dc at 0.3 amps. 250 v dc at 6.5 ma or 300 v dc at 7.5 ma.*

**356B-1 PROGRAM/MONITOR AMPLIFIER**—High fidelity makes 356B-1 excellent for program and monitor amplifier use. Three stage amplifier with push-pull output, high or low gain. *Input Impedance: 150/600 ohms. Output Impedance: 150/600 ohms. Input Level: -32 dbm. Output Level: +30 dbm to 8 watts (+39 dbm). Gain: 56 or 68 db, selectable by switch. Noise: -116 dbm at input. Power Requirements: 6.3 v ac at 1.2 amps. 63 ma at 250 v dc at 1 watt output. 75 ma at 300 v dc at 1 watt output. 88 ma at 300 v dc at 8 watts output.*

**274K-1 RELAY SUBUNIT**—Contains four relays to control studio speakers and warning lights. *Power Requirements: 12 v dc, 560 ma supplied by 409X-1. Warning light power supplied by studio wiring.*

**409X-1 POWER SUPPLY**—Supplies power for 212E-1 and 212F-1 and subunits. *Output Voltages: Up to 250 ma at 300 v dc adjustable. 6.0 amps at 6.3 v ac. 12 v dc. Primary Power: 115/230 v  $\pm$ 10%, 1 phase, 50/60 cps, 225 watts max.*

**409Y-1 POWER SUPPLY**—May be used as a second power supply when maximum facilities of 212E-1 are utilized. *Output Voltages: Up to 100 ma at 300 v dc, adjustable. 3 amps at 6.3 v ac. Primary Power: 115/230 v, 1 phase, 50/60 cps, 85 watts max.*

**356E-1 LIMITING AMPLIFIER**—This optional subunit acts as automatic average level or average limiting amplifier. Ideal for unattended operation, it may also be used to control level differences between two or more sources or serve as program line compressor or amplifier. *Input Impedance: 150/600 ohms. Output Impedance: 150/600 ohms. Gain: 54 db. Compression Ratio: Adjustable 1.6/1 to 5/1, 3/1 optimum, over 30 db range at input. Attack Time: 11 msec, dual operation. 62 msec, average operation. Release Time: 0.9 sec for 63% recovery, dual operation. 5.2 sec for 63% recovery, average operation. Noise: -50 dbm or less (threshold set at  $\pm$ 20 dbm). Power Requirements: 6.3 v ac at 1.55 amps. +300 v dc at 77 ma.*

**499G-1 RACK MOUNTING SHELF**—Offers a flexible facility for rack mounting of amplifier, relay and power supply subunits for fully expanded facilities of 212E-1.

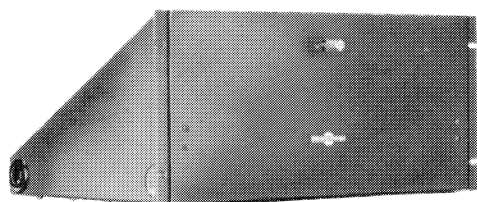

499G-1

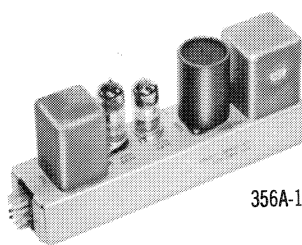

356A-1

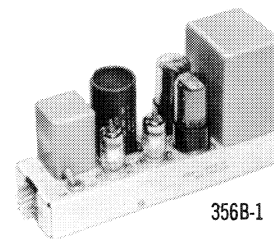

356B-1

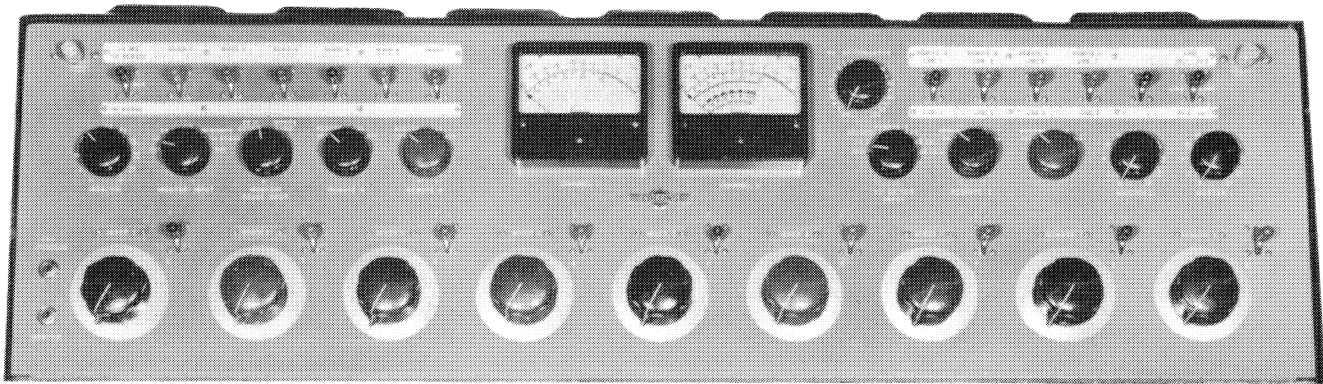

212E-1

	Type	Frequency Response	Distortion	Size (inches)			Weight (lbs.)
				W	D	H	
Speech Input Console	212E-1	± 1.5 db, 50-15,000 cps at program line	Less than 1% at +18 dbm at program line Less than 3% at 8 watts out of monitor amplifier	41½	22½	11	135
Speech Input Console	212F-1	± 1.5 db, 50-15,000 cps at program line	Less than 1% at +18 dbm at program line Less than 3% at 8 watts out of monitor amplifier	35	22	10¼	100
Preamplifier Subunit	356A-1	± 1 db, 50-15,000 cps	0.5% max.	2½	9½	4¾	2¼
Program/Monitor Amplifier Subunit	356B-1	± 1 db, 50-15,000 cps	0.5% max. at +30 dbm 3% max. at 8 watts (+39 dbm)	2¾	9½	5¾	6
Relay Subunit	274K-1			2½	9	5½	2½
Power Supply Subunit	409X-1			8	9½	6	25
Power Supply Subunit	409Y-1			5½	9½	5¾	10¾
Limiting Amplifier Subunit	356E-1	± 1 db, 50-50,000 cps	1.5% max., 50-15,000 cps, no compression 2% max., 50-15,000 cps, up to 30 db reduction, threshold at +20 dbm output	3	9	5¾	5
Rack Mounting Shelf	499G-1			19	14	8¾	11

212F-1

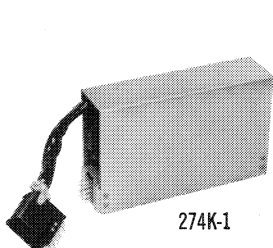
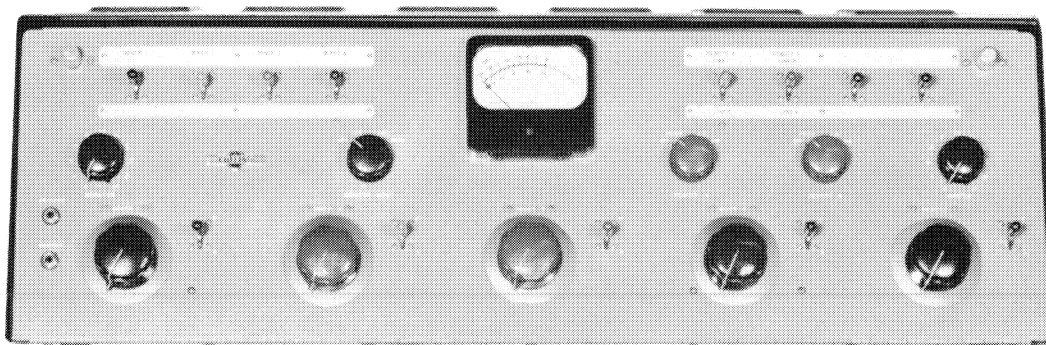

274K-1

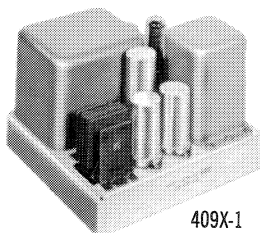

409X-1

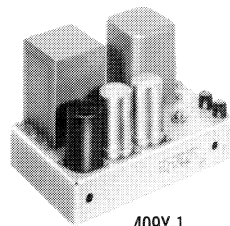

409Y-1

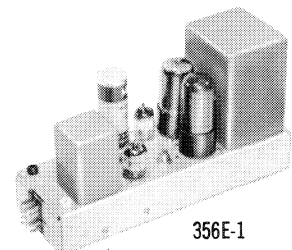

356E-1

# SPEECH EQUIPMENT

**212Z-1 REMOTE AMPLIFIER** — Weighing a total of 22 pounds including batteries and carrying case, the 212Z-1 offers full functions for remote broadcasts. This transistorized remote amplifier mixes inputs from up to four microphones, with program line and communication line outputs as well as an auxiliary output for PA feed. The unit operates from 115 v ac or self-contained batteries, with automatic changeover on failure and restoration of ac. Battery life is approximately 75 hours. The 212Z-1 provides a maximum gain of 90 db. It employs step faders rather than composition type faders. Incorporated in the unit is a 400 cps tone oscillator to assist in setting up line level. A low, sloping panel with convenient controls and plastic write-in strips simplifies operation. All terminals and jacks except line and program monitors are located at the rear of the unit. Two 212Z-1's may be connected together and operated simultaneously, controlled by one master gain knob. *Input Impedance:* 25-600 ohms. *Output Impedance:* 600 ohms (150 available). *Frequency Response:*  $\pm 1.5$  db 50-15,000 cps. *Distortion:* Less than 1.5% at +5 dbm. *Noise:* 55 db below normal output level (-115 dbm equivalent input noise figure). *Power Output:* Normal — +11 dbm. Emergency — +16 dbm. *Primary Power:* 115/230 v (115 supplied), 50/60 cps, or self-contained batteries (not supplied). *Size:* 15½" W, 14½" D, 6½" H.



212Z-1

**'MICROMOTE' REMOTE AMPLIFIER** — Though only slightly larger than a pack of cigarettes, this high performing remote is excellent for one-man, one-mike situations. The "Micromote" is completely transistorized, weighing only 10 oz. including ear plug headphone and mike connector. Constructed of sturdy chrome finished steel, the "Micromote" contains 6 transistors and 4 mercury batteries with average life of over 200 hours. It includes a gain control and built-in test light which will operate as long as 12 hours' battery life remains. *Input Impedance:* 50-250 ohms. *Output Impedance:* 600 ohms. *Frequency Response:*  $\pm 1$  db 70-15,000 cps. *Distortion:* Less than 1%. *Noise:* 80 db below +12 dbm output. *Gain:* 85 db. *Power Output:* +12 dbm. *Size:* 2¼" W, ¾" D, 3⅝" H.

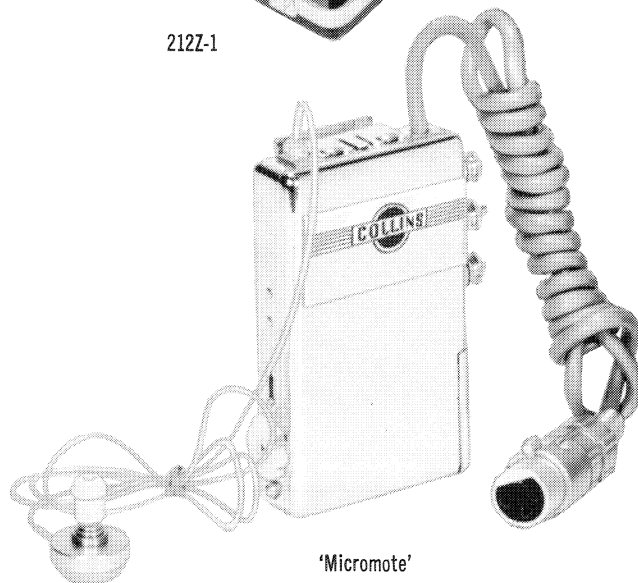

'Micromote'

**TT-400, -200 TURNTABLES** — Four models include: TT-400 — 16", four pole motor; TT-400S — 16", synchronous motor; TT-200 — 12", four pole; TT-200S — 12", synchronous. All offer the utmost simplicity with only three moving parts in the drive mechanism. Units are constructed of heavy cast aluminum with blue-gray wrinkle finish, and the turntables are non-magnetic. A gear speed shift offers selection of 33, 45 and 78 rpm, with neutral between slots. An indentation in the turntable eliminates the need for a spindle adapter for 7" 45 rpm records. Wow and rumble are greatly reduced by a double-ball thrust bearing. *Noise:* Better than 50 db below normal program level. *Speed Regulation:* Better than 0.25% over-all. *Size:* TT-400 — 2" above table, 6" below table, over-all base 19⅝" square. TT-200 — 1½" above table, 4¼" below, base 14½" x 15½". *Weight:* TT-400 — 53 lbs. TT-200 — 22 lbs.

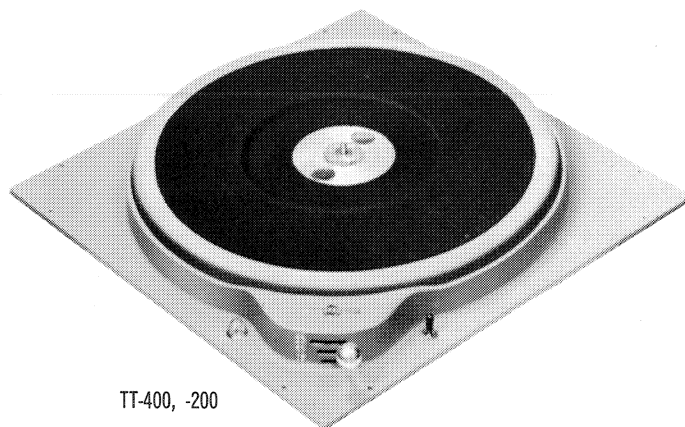

TT-400, -200

# SPEECH EQUIPMENT

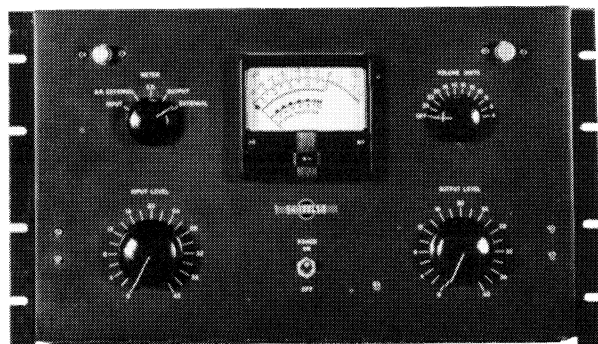

26U-1

**26U-1 LIMITING AMPLIFIER** — The 26U-1 provides control of the amplitude of audio frequency peaks in AM or FM broadcasting as well as in recording and quality PA systems. Distortion and noise in the unit are very low. Controls are provided for adjustment of input and output levels, with an illuminated 4" VU meter and variable attenuator enabling a visual indication of input and output levels and amount of compression in db. The meter will also measure external audio levels and gain reduction when used with the 356E-1 Limiting Amplifier. *Frequency Response:*  $\pm 1.5$  db 50-15,000 cps. *Distortion:* Harmonic 1.5% max. at 25 db compression. *Input Impedance:* 600 ohms unbalanced. *Output Impedance:* 600 ohms balanced or unbalanced. *Input Level:* -20 to +20 dbm. *Compression Ratio:* 12/1 first 10 db above verge of compression. *Attack Time:* Adjustable 0.5-3.0 msec. *Release Time:* Adjustable 2.2-5.2 sec. *Output Noise:* -60 dbm. *Primary Power:* 120/130 v, 50/60 cps. *Size:* 19" W, 9" D, 10½" H.

**151K-1 TERMINAL BOARD** — Used in the base of rack mounting cabinets, this board contains 96 telephone type solder terminals for audio connections and 60 heavy duty threaded stud type terminals for power connections. *Weight:* 2 lbs. 14 oz.

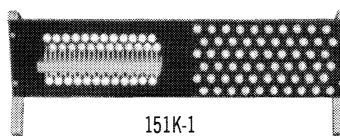

151K-1

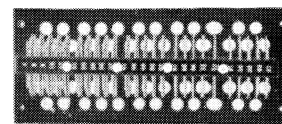

151K-5

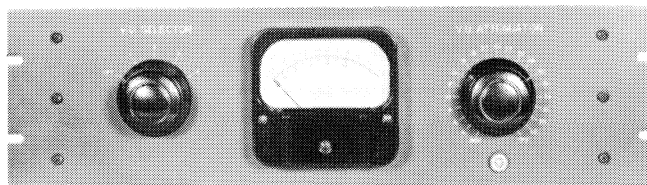

62E-1

**151K-5 TERMINAL BOARD** — Provides 100 telephone type terminals, 25 in a row, 4 rows deep, on a bakelite board. *Size:* 8" W, 3½" H (mounting centers 7½" x 2½"). *Weight:* 1 lb.

**151K-6 TERMINAL BOARD** — Similar to the 151K-1, but provides 144 telephone type terminals and 60 heavy duty terminals. *Weight:* 3 lbs.

**62E-1 VU PANEL** — The 62E-1 accurately monitors audio levels in broadcasting, recording and sound systems. It has a standard, easily read 4" VU meter with type A scale. Over-swing is slight and pointer action deliberate and positive. Designed to operate on a 600 ohm line, the 62E-1 will also accommodate other impedances with the use of a calibration chart. *Inputs:* 4. *Input Impedance:* 7,500 ohms constant except on 1 mw calibration position. *Primary Power (Meter Illumination):* 6.3 v ac or dc, 0.3 amp. *Size:* 19" W, 5¼" H. *Weight:* 9 lbs.

**BLANK PANELS** — Standard panels are available in several heights, constructed of 3/16" aluminum, drilled to mount in 19" racks and finished in metallic gray. Others on special order.

## CUSTOM CONTROL DESKS

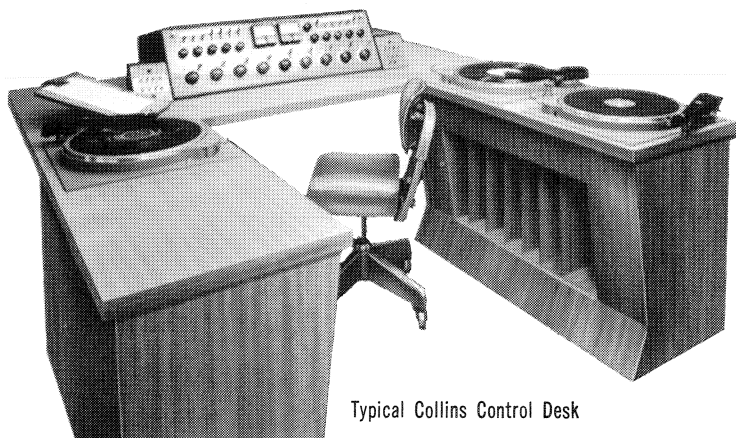

Typical Collins Control Desk

Attractiveness is combined with operational efficiency and economy in Collins control desks, custom designed to each broadcaster's requirements. These desks are sturdily constructed of wood and covered with any of a wide range of patterns of long lasting Formica. Among the features that may be incorporated without sacrificing attractiveness are adjustable feet, built-in record compartments, hidden console cables and provisions for rack mounting. Collins will provide free estimates upon submission of the physical layout of the studio and an outline of functions desired for inclusion in the desk.



# TV-STL MICROWAVE

Collins TV Studio-to-Transmitter Link Systems transmit NTSC color or monochrome and high fidelity audio in the 6875-7125 mc band. Systems are also available in the 5925-6425 mc, 6575-6875 mc and 7125-7600 mc bands. Servicing is simplified by easily accessible controls, numerous test points, plug-in subunits and complete metering. Standby units or additional channels may be added to the same rack, with transmitters or receivers stacked on a common waveguide. Parabolic antenna may be mounted as much as 75 feet from RF unit, enabling a complete indoor installation. Equipment features long life reflex klystron, fixed tuned IF amplifier, high fidelity FM modulator. *Power Output:* 100 mw min. *Carrier Deviation:*  $\pm 3$  mc nom. *Receiver Sensitivity:*  $-118$  dbw. *Receiver Noise Figure:* 14 db or less. *Receiver Bandwidth:* 14 mc to 3 db points. *Video Frequency Response:* Video Only —  $\pm 0.2$  db 60 cps-3 mc;  $\pm 0.5$  db to 4.2 mc;  $\pm 2$  db to 6 mc. With Sound Channel —  $\pm 0.5$  db to 4.2 mc (sound notch at 6.5 mc). *Video Emphasis Characteristic:* 12 db symmetrical about 400 kc. *Audio Frequency Response:*  $\pm 0.5$  db 50 cps-13 kc;  $\pm 2$  db 20 cps-15 kc. *Audio Distortion:* Less than 1%. *Audio Sub-carrier Emphasis:* 75 usec (standard FM curve). *Primary Power:* 115 v, 1 phase, 50/60 cps.

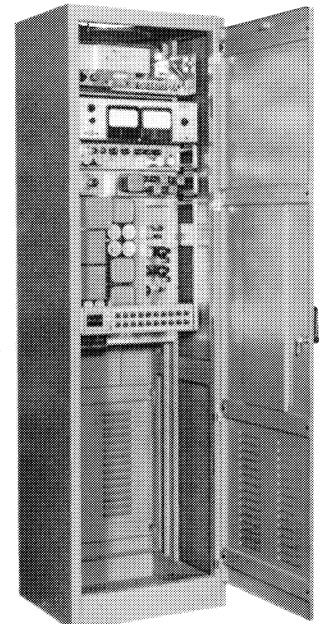
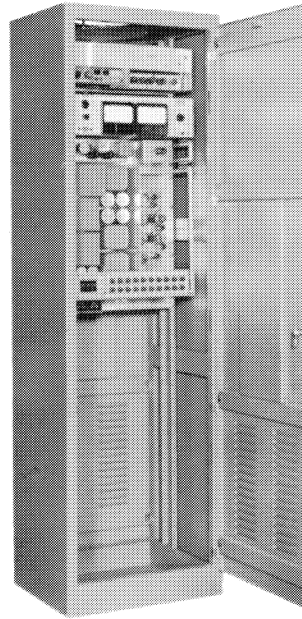

Receiving Terminal  
Transmitting Terminal

# WEATHER RADAR

TV weathercasters can add new realism to their programs by showing actual weather conditions live with Collins Weather Radar. Operation in the C band assures high storm penetration. Local map slides superimposed on the radar indicator enable viewers to pinpoint the locations of storms. Cells of high precipitation and turbulence within these storms may be further defined by using the radar's "contour" circuitry. Full coverage of the area is provided, with selectable ranges of 20, 50 and 150 nautical miles. *Primary Power:* 115 v  $\pm 5\%$ , 380-420 cps, 665 va (1 indicator), 790 va (2 indicators) (alternator available). 28 v dc, 1 amp max. (relay).

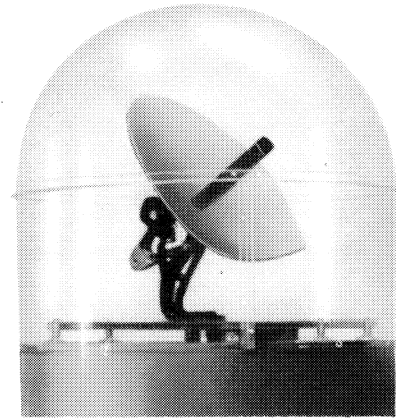

537F-3 with Radome

**537F-3 ANTENNA** — Mounted on roof. 30" parabolic dish with  $5\frac{1}{2}^\circ$  beamwidth.  $360^\circ$  rotation at 15 rpm. In normal TV installation, may be tilted  $15^\circ$  above and  $10^\circ$  below horizontal reference plane, with full  $25^\circ$  above available by adjustment. *Size:*  $31\frac{1}{2}$ " W,  $31\frac{1}{2}$ " D,  $36\frac{3}{8}$ " H. *Weight:* 30.7 lbs.

**493A-1 INDICATOR** — A Plan Position Indicator with 5" tube. *Size:*  $6\frac{1}{4}$ " W,  $12\frac{1}{2}$ " D,  $6\frac{1}{4}$ " H. *Weight:* 11.8 lbs.

**561G-2 CONTROL** — Central control for system. *Size:*  $5\frac{3}{4}$ " W, 3" D,  $3\frac{3}{8}$ " H. *Weight:* 1.4 lbs.

**374A-1 RECEIVER-TRANSMITTER** — Includes all RF and IF circuits. *Frequency:* 5400 mc  $\pm 30$  mc. *Power Output:* 75 kw peak, min. *Size:*  $10\frac{1}{8}$ " W,  $22\frac{1}{8}$ " D,  $7\frac{5}{8}$ " H. *Weight:* 54 lbs.

**776C-1, -2 SYNCHRONIZERS** — 776C-1 used in 1 indicator systems; 776C-2 in 2 indicator systems. *Size:*  $10\frac{1}{8}$ " W,  $22\frac{1}{8}$ " D,  $7\frac{5}{8}$ " H. *Weight:* 776C-1 — 34.9 lbs. 776C-2 — 38.4 lbs.

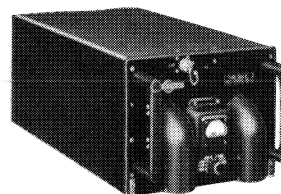

374A-1

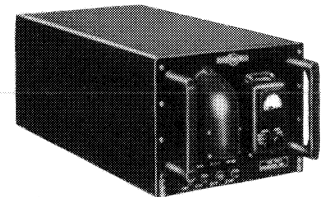

776C-1

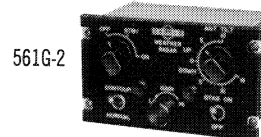

561G-2

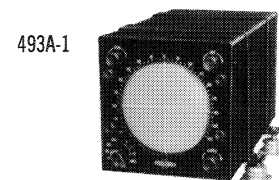

493A-1